

AVAILABLE IMMEDIATELY



12' x 56'
Modular Housing
4 Units per Building

Ideal for Emergency Personnel, First Responders, FIRST AID STATIONS, Police, Fire & Rescue, All Relief Operations

Four complete single rooms per unit, each with a full bath.

Sound insulated between rooms for privacy.

Thoroughly compact and designed for extended stay use.

Call 24/7: 214-454-3504



MORGAN BUILDING SYSTEMS

For Permanent or Temporary Housing

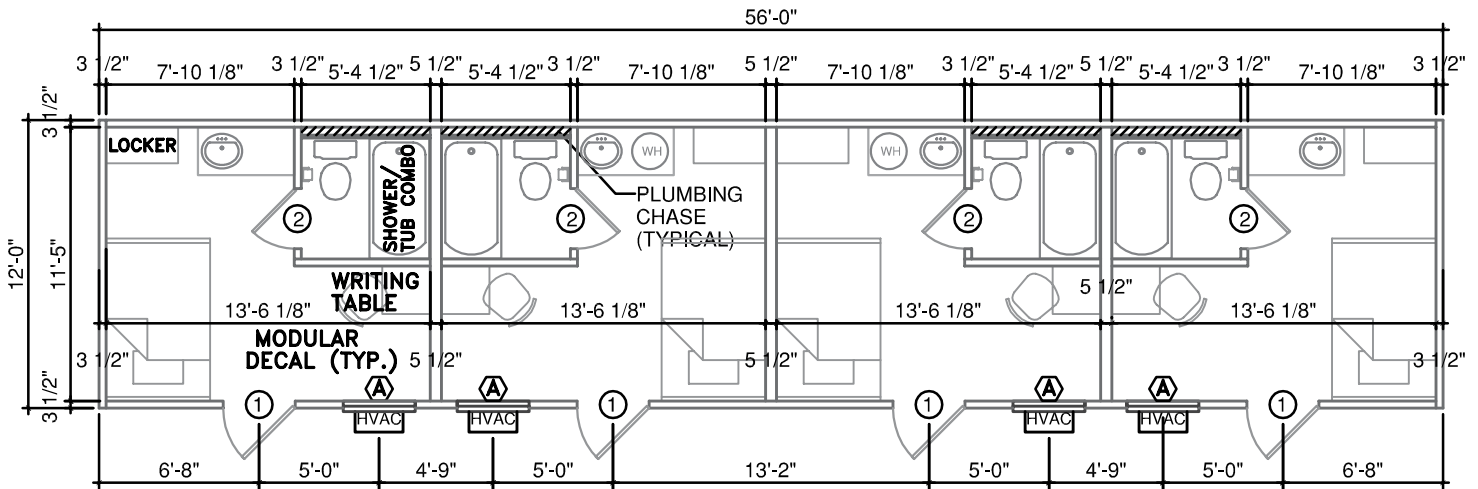

- Each room has full bath
- Sound isolated for privacy
- Pressure treated floors built to IBC codes and sealed
- Insulated industrial steel exterior doors (will support electronic style locks)
- Sprinkler equipped fire suppression
- Rear utility access
- Energy efficient photo cell exterior lighting
- HVAC in each room
- Exterior LP smart panel siding
- Seamless flooring
- Roof roll-lock Galvalume® standing seam metal over plywood
- Very little site work required

Financing Available



For Information, visit your local Morgan sales office or our website

For 24 Hour Emergency Service, Call:



MORGAN BUILDING SYSTEMS

Since 1961

2800 McCree Rd.

Garland, TX 75041

972-864-7300

morganbuildingsystems.com

Jim Schilligo

General Sales Manager

972-864-7300 x7341 (office)

214-697-3007 (cell)

jschilligo@morganusa.com

Andrew Morgan

Commercial Sales

214-454-3504 (cell)

972-864-7322 (office)

atmorgan@morganusa.com

Cody Morgan

Commercial Sales/Engineering Mgr.

972-864-7300 x7338 (office)

214-213-2691 (cell)

cmorgan@morganusa.com